

EN

ZECA



TECHNICAL EXCELLENCE. SINCE 1929.

242 AUTOMOTIVE CATALOGUE

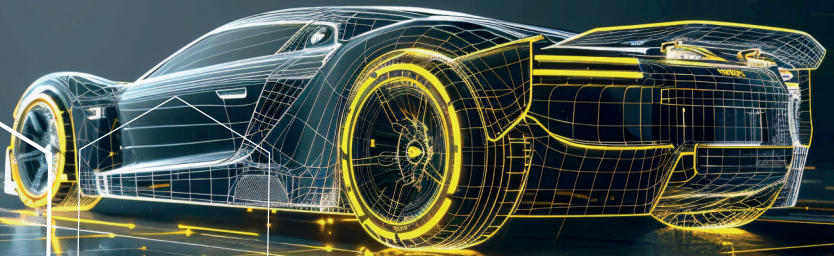

HOSE REELS



804 - 805 SERIES
p. 12



805 SAFE SERIES
p. 12



805 FLEX SERIES
p. 13



AM80 AM85
SERIES p. 16



AL SERIES
p. 18



AL 81 - AL83
BLACK SERIES
p. 19



AM86 SERIES
p. 20



8400 SERIES
p. 24



9100 SERIES
p. 29

LAMPS



39401
p. 30



345
p. 31



342
p. 32



330
p. 33



328
p. 34



329
p. 35



370
p. 36



306
p. 37

EXTENSION REELS p. 52



GARAGE TOOLS



**RADIATOR
TESTER**
p. 38



**RADIATOR
FILL**
p. 39



**COMPRESSION
TESTER**
p. 40



**DIESEL
INJECTOR TESTER**
p. 42



**EXHAUST GAS
EXTRACTOR**
p. 44



FILLER
p. 45



**COOLANT
ANTI-FREEZE
TESTER**
p. 46



**TOOL FOR
CLUTCH
PLATES**
p. 46



**COMPRESSED
AIR VALVE
GRINDER**
p. 46



**BATTERY
EQUIPMENT**
p. 47



**BATTERY
TESTER**
p. 48



**SPIKE
SUPPRESSOR**
p. 49



**SAFETY
BARRIERS REEL**
p. 50

INDUSTRIAL CABLE REELS



**9000
SERIES**
p. 55



**4000
SERIES**
p. 56



**7000
SERIES**
p. 57



**AL BLACK
SERIES**
p. 58

CABLE REELS FOR BATTERY CHARGERS

EV SERIES
p. 59



**FOR BATTERY
CHARGER**
63

ZECA



Since 1929, Zeca has responded with excellent products to the needs of anyone who works in garages, industry and on construction sites.

At the Feletto plant in the province of Turin we produce cable reels, hose reels, lamps, extensions, balancers and garage tools.

Our products are recognised in Italy and worldwide for their practicality, durability and above all for their safety, even in extreme situations of use.

We are a leader in the production of reels, but over the years our range has expanded to numerous other references, to meet all of our customers' requirements.



**90 countries
world wide**

served by
our products,
across
5 continents



OUR COMPANY

The Zeca production plants, logistics warehouses and offices have been expanded several times over the years, in parallel with the constant growth of the company.

Today they occupy 4 interconnected plants, with more than 15 thousand m² of total indoor space. A good 300 m² are dedicated to our exclusive research and development laboratory, where we perform numerous in-house quality and durability tests.



4 Production plants

Total covered area
+ 17,000 sqm

Total area
170,000 sqm



Management System
ISO 9001:2015
ISO 14001:2015
ISO 45001:2018



www.tuv.com
ID: 9108643481



Since 1929, **ITALIAN TECHNICAL EXCELLENCE**

Zeca is a story of more than 90 years of commitment, passion, responsibility and innovation that has involved four generations, always projected to the future. In 1929, in a small repair and spare parts workshop for cars and motorcycles in Rivarolo Canavese, there was already a spirit of innovation. Carlo Zerbinì and his son Luciano gave life to a technical laboratory that will change their present and inspire the future of their family.

1919

CARLO ZERBINI
opened a repair workshop for cars and motorcycles in Rivarolo Canavese



ZECA

1929

ZECA BEGAN TRADING
the production of accessories and tools for motor vehicles began with the name Zeca (from Zerbinì Carlo)

1944

LUCIANO ZERBINI,
son of Carlo, assumed presidency and introduced new products into the catalogue



1969

LUCIANO DIED PREMATURELY
His 20-year old daughter Carla assumed Presidency with the assistance of Sergio Antonietto



1954

SERGIO ANTONIETTO
joined the company. His presence would be vital for the future success of the business.



1973 PIERO CHIARABAGLIO

Carla's husband, joined the company as Technical Director. Giancarlo, Luciano's youngest son, began his 20 years of work at Zeca



1960

NOW IT WAS TIME TO MOVE
to a larger plant where innovative and functional products would be created

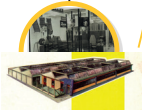

1980

AND NOW THE TIME HAD COME TO MOVE
Zeca and transfer to the new and more functional plant at Feletto covering 7,500 sqm.



1990

NEW LOGO
The Zeca brand continued to increase its presence on the market. It assumed the colours of yellow and black



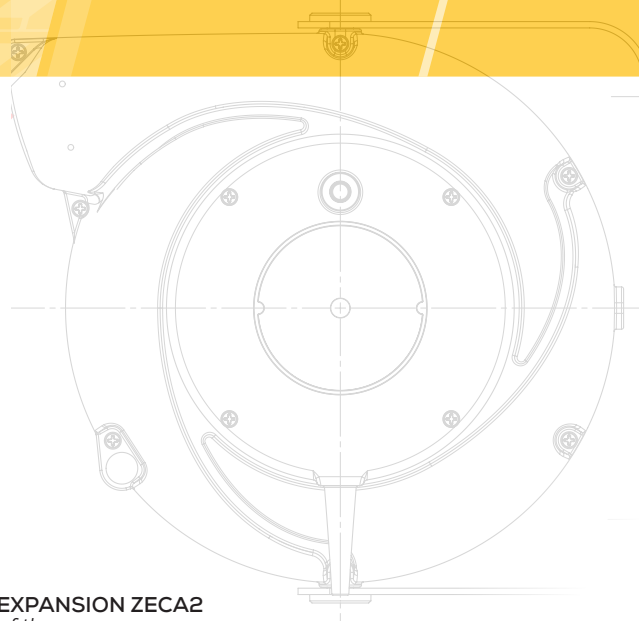

1997

ZECA IN EXPANSION ZECA2

Opening of the new warehouse of 4,000 sqm: Zeca 2



2006

ZECA CREATED THE NEW ZETEK BRAND

to satisfy the emerging needs of the market



2000

NEW AND SUCCESSFUL PRODUCTS WERE CREATED
a new "diabolic" rechargeable LED lamp

2008

OPENING OF ZECA 3

Opening of Zeca 3, the new warehouse measuring 3,700 sqm.



2010

THE NEW CEOS PAOLO AND MARCO CHIARABAGLIO

assumed presidency of the company that by now was exporting globally



2019

EV SERIES

Zeca presented its first cable reel with built-in wallbox for green mobility



2024

ZECA PLASTIC DIVISION

internal plastic molding



57

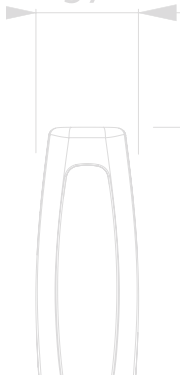

2018

**ISO 9001
14001 -45000
CERTIFICATIONS**

➤ KPU HOSE EXCLUSIVE TO ZECA

➤ FLEX HOSE



HIGHLY DURABLE
SUBSTRATE

ANTISTATIC SLEEVE

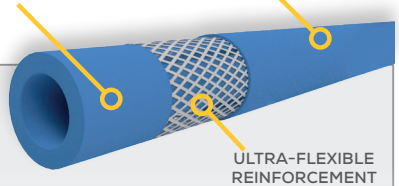

ULTRA-FLEXIBLE
REINFORCEMENT

ULTRA-FLEXIBLE HOSE FOR VEHICLE BODYWORK

The Flex hose is designed for intensive and daily use in body shops, ship fitting yards, and all work environments where a flexible and lightweight hose is indispensable.

Maximum working pressure: 15 bar
Hose working temperature: -40°C +60°C

ART.	DIAMETER	LENGTH	COLOURS
82/8FX/100	8 mm - (5/16")	100 m	●
82/10FX/100	10 mm - (3/8")	100 m	●

➤ FLEX HOSE



ART.	DIAMETER	FITTINGS	LENGTH	COLOURS
FLEX/8-10	8 mm - (5/16")	1/4" M BSP	10 m	●
FLEX/8-15	10 mm - (3/8")	1/4" M BSP	15 m	●
FLEX/10-10	8 mm - (5/16")	3/8" M BSP	10 m	●
FLEX/10-15	10 mm - (3/8")	3/8" M BSP	15 m	●

KPU HOSE



POLYESTER-BASED
POLYURETHANE

SPECIAL POLYURETHANE
BLEND

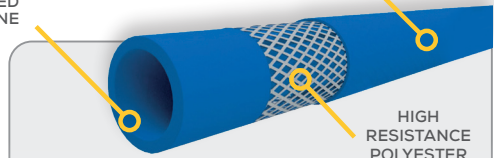

HIGH
RESISTANCE
POLYESTER

Flexible hose resistant to both external chemical agents and mechanical stresses, designed for industrial automation, pneumatic tools, workshops, and heavy-duty environments.
Maximum working pressure: 20 bar
Hose working temperature: -15°C +65°C

ART.	DIAMETER	LENGTH	COLOURS
82/8BU/120	8 mm - (5/16")	120 m KPU	●
82/10BU/100	10 mm - (3/8")	100 m KPU	●
82/13BU/120	12,5 mm - (1/2")	120 m KPU	●
82/8BK/120	8 mm - (5/16")	120 m KPU	●
82/10BK/100	10 mm - (3/8")	100 m KPU	●
82/13BK/120	12,5 mm - (1/2")	120 m KPU	●
82/8RD/120	8 mm - (5/16")	120 m KPU	●
82/10RD/100	10 mm - (3/8")	100 m KPU	●
82/13RD/120	12,5 mm - (1/2")	120 m KPU	●

SAFE HOSE



POLYESTER-BASED
POLYURETHANE

HIGH VISIBILITY SPECIAL
POLYURETHANE BLEND

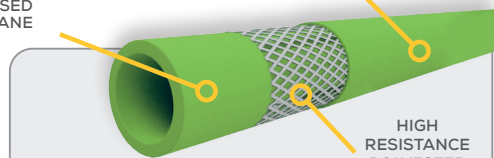

HIGH
RESISTANCE
POLYESTER

HIGH-VISIBILITY KPU Hose

Flexible hose, high-visibility lime color.
 Resistant to both external chemical agents and mechanical stresses, designed for industrial automation, pneumatic tools, workshops, and heavy-duty environments.
Maximum working pressure: 20 bar
Hose working temperature: -15°C +65°C

ART.	DIAMETER	LENGTH	COLOURS
82/10LM/100	10 mm - (3/8")	100 m KPU	●



NEW SPECIFICALLY-DESIGNED INLET FITTING



WATCH THE VIDEO ON ZECA.IT

ART.	DIAMETER
82/KIT 8 KPU	8 mm - (5/16")
82/KIT 8 FLEX	8 mm - (5/16")
82/KIT 10 KPU	10 mm - (3/8")
82/KIT 10 FLEX	10 mm - (3/8")
82/KIT13	13 mm - (1/2")

SAFETY RETURN



Safety Return slows the retraction of the hose, preventing kickback should the hose accidentally slip out of the user's hand. Safety Return is an optional braking device

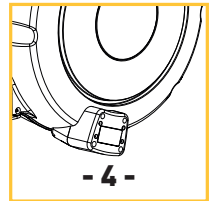
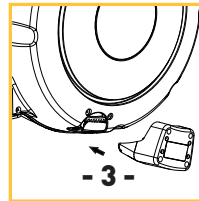
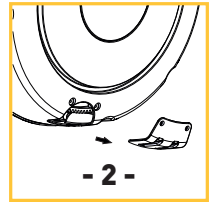
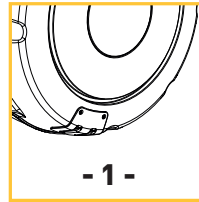

OPTIONAL
805/SR - AL83-AM85/SR - AM86/SR
AN EXTRA GUARANTEE WITH **SAFETY RETURN**

THERE ARE RISKS



ONE CAN AVOID





EASY SET-UP

THE REEL CAN BE MOUNTED BY ONE PERSON IN JUST A FEW MINUTES

1

2

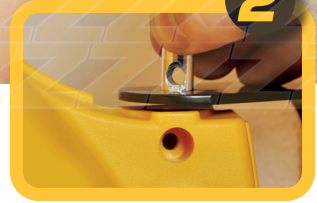

3



NEW QUICK FIT

FEATURE QUICKLY CONNECT THE REEL TO ITS BRACKET

ON SERIES
805 - 7000



804



KPU HOSE



BEST AIR FLOW



805



TECHNICAL FEATURES



ISO EN 12100



2006/42/EU

- Technopolymer casing.
- Metal, adjustable fastening bracket.
- Provided with hose ratchet stop device, easily removable if constant traction is required.
- KPU hose.



805 SAFE

The SAFE version is added to the 805 hose reel family, which, thanks to its highly visible and vibrant lime green hose, stands out and can be easily discerned in dimly lit environments, reducing the risk of tripping. In situations where it is necessary to leave the hose unwound, it ensures order and minimises the risk of wear and damage to the hose.

KPU HOSE



TECHNICAL FEATURES

- KPU hose
- Technopolymer casing.
- Metal, adjustable fastening bracket.
- Provided with hose ratchet stop device, easily removable if constant traction is required.

805 FLEX

ULTRA-FLEXIBLE HOSE FOR VEHICLE BODYWORK

Zeca's new **Flex** hose is designed for intensive, daily use in vehicle bodywork shops and all working environments where a flexible, lightweight hose is essential. The zero memory effect minimises the risk of accidental collision with object, and the antistatic compound does not attract dust and paint particles.



TECHNICAL FEATURES

- FLEX hose
- Technopolymer casing.
- Metal, adjustable fastening bracket.
- Available in light blue and yellow
- Provided with hose ratchet stop device, easily removable if constant traction is required.

ISO EN 12100



2006/42/EU

805 NITROGEN

The 805 family is expanding with a new model dedicated to nitrogen: the 805/10 N₂. The black KPU hose and the green sleeve ensure immediate identification of the type of gas being dispensed, making the work environment safer and more organized.



ISO EN 12100



2006/42/EU



SAFETY RETURN

AN EXTRA
GUARANTEE WITH

■ OPTIONAL
ART. 805/SR

The Safety Return braking system slows the retraction of the hose into the case, preventing kickback should the hose accidentally slip out of the user's hand. Safety Return is an optional braking device for the Zeca 805 series.

804 SERIES



805 SERIES



ART. BLACK	804/8/B	804/10/B	805/8/B	805/10/B	805/13/B
-------------------	----------------	-----------------	----------------	-----------------	-----------------



ART. SILVER	804/8/S	804/10/S	805/8/S	805/10/S	805/13/S
--------------------	----------------	-----------------	----------------	-----------------	-----------------



ART. YELLOW	804/8	804/10	805/8	805/10	805/13
Hose Int. Ø	8 mm (5/16")	10 mm (3/8")	8 mm (5/16")	10 mm (3/8")	12,5 mm (1/2")
Hose length	10 m	8 m	16 m	16 m	11 m
Max press	15 bar				
End hose fitting	1/4" M BSP	3/8" M BSP	1/4" M BSP	3/8" M BSP	1/2" M BSP
Temperature	-5 °C/+50 °C				
Incoming hose fitting	SI				NO
Incoming hose	1,5 m				
Suitable for	Air - Water				
Hose type	KPU				
Hose color	BLEU				
	44		20		
	mm 360x310x185 - Kg 4		mm 450x400x230 - Kg 7		



NEW
SPECIFICALLY-DESIGNED
INLET FITTING INCLUDED



WATCH THE
VIDEO ON
ZECA.IT



dimensions 804

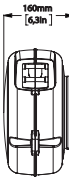
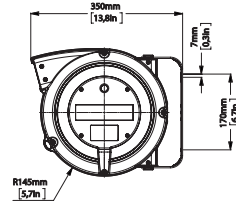

dimensions 805

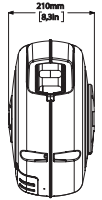
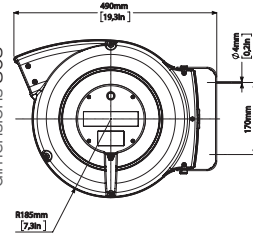

OPTIONAL

ART.
949/804-4000

ART.
949/805-7000
Optional device
to fasten the
pivoting bracket



**805/8/A
FLEX**

**805/10/A
FLEX**



ART.	805/8 FLEX	805/10 FLEX	805/8/B SAFE	805/10/B SAFE	805/10 N2
Hose Int. Ø	8 mm (5/16")	10 mm (3/8")	8 mm (5/16")	10 mm (3/8")	10 mm (3/8")
Hose length	15 m	15 m	16 m	16 m	16 m
Max press	15 bar				
End hose fitting	1/4" M BSP	3/8" M BSP	1/4" M BSP	3/8" M BSP	3/8" M BSP
Temperature	-5 °C/+60 °C		-5 °C/+50 °C		
Incoming hose fitting	SI				
Incoming hose	1,5 m				
Suitable for	Air - Water				
Hose type	FLEX		KPU SAFE		KPU
Hose color	AZURE		LIME		BLACK
	20				
	mm 450x400x230 - Kg 7				

AM80



AM85



TECHNICAL FEATURES

- Black polyurethane hose.
- Technopolymer casing.
- Metal, adjustable fastening bracket. .
- Provided with hose ratchet stop device, easily removable if constant traction is required.

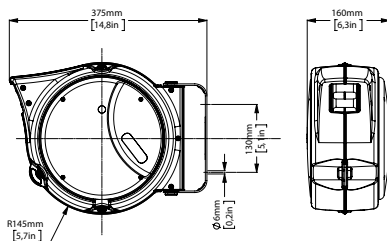

dimensions AM80

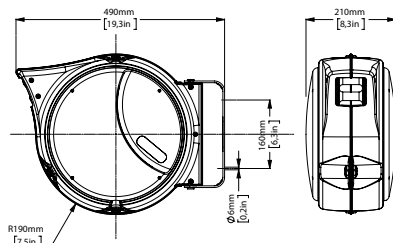

dimensions AM85





ART.	AM80/8	AM85/8	AM85/10
Hose Int. Ø	8 mm (5/16")	8 mm (5/16")	10 mm (3/8")
Hose length	10 m	16 m	16 m
Max press	15 bar	15 bar	15 bar
End hose fitting	1/4" M BSP	1/4" M BSP	3/8" M BSP
Temperature	-5 °C/+40 °C	-5 °C/+40 °C	
Incoming hose fitting	NO	NO	
Incoming hose	1,5 m	1,5 m	
Suitable for	Air	Air	
Hose type	PU	PU	
Hose color	Black	Black	
	40	20	
	mm 390x330x230 Kg 4	mm 500x430x245 Kg 7	

■ **OPTIONAL FOR AM80**
ART. 949/AL41-AM40

Optional device to fasten the pivoting bracket. of AM80 reel.



AL SERIES



- Die-cast aluminium structure with epoxy powder coating.
- Metal, adjustable fastening bracket.
- Provided with hose ratchet stop device, easily removable if constant traction is required.

ISO EN 12100



2006/42/EU

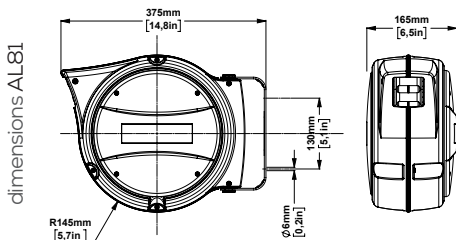

AL81
AL83

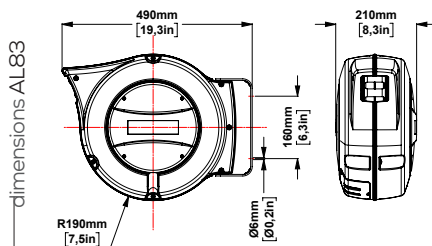

ART.	AL81/8	AL81/10	AL83/8	AL83/10	AL83/13
Hose Int. Ø	8 mm (5/16")	10 mm (3/8")	8 mm (5/16")	10 mm (3/8")	12,5 mm (1/2")
Hose length	10 m	8 m	16 m	16 m	11 m
Max press	15 bar	15 bar	15 bar	15 bar	15 bar
End hose fitting	1/4" M BSP	3/8" M BSP	1/4" M BSP	3/8" M BSP	1/2" M BSP
Temperature	-5 °C/+50 °C		-5 °C/+50 °C		
Incoming hose fitting	NO		NO		
Incoming hose	1,5 m		1,5 m		
Suitable for	Air - Water		Air - Water		
Hose type	KPU		KPU		
Hose color	BLUE		BLUE		
	44		20		
	mm 360x310x185 - Kg 6		mm 450x400x230 - Kg 9		

OPTIONAL



ART. AL83-AM85/SR Safety Return slows the retraction of the hose, preventing kickback should the hose accidentally slip out of the user's hand. **Safety Return is an optional braking device for the AL83 series.**

ART. 949/AL41-AM40 Optional device to fasten the pivoting bracket. For AL81

AL81

BLACK





ART.	AL81/8/B	AL81/10/B	AL81/8/B SAFE	AL81/10/B SAFE
∅ internal hose	8 mm (5/16")	10 mm (3/8")	8 mm (5/16")	10 mm (3/8")
Hose length (m)	10 m	8 m	10 m	8 m
Max press.	15 bar	15 bar	15 bar	15 bar
Outlet fitting	1/4" M BSP	3/8" M BSP	1/4" M BSP	3/8" M BSP
Temperature	-5 °C/+50 °C		-5 °C/+50 °C	
Incoming hose fitting	NO			
Incoming hose	1,5 m			
Suitable for	Air - Water			
Hose type	KPU		KPU SAFE	
Hose colour	BLUE		LIME GREEN	
	44			
	mm 360x310x185 - Kg 6,0			

AL83

BLACK



ART.	AL83/8/B	AL83/10/B	AL83/8/B SAFE	AL83/10/B SAFE
∅ internal hose	8 mm (5/16")	10 mm (3/8")	8 mm (5/16")	10 mm (3/8")
Hose length (m)	16 m		16 m	
Max press.	15 bar		15 bar	
Outlet fitting	1/4" M BSP	3/8" M BSP	1/4" M BSP	3/8" M BSP
Temperature	-5 °C/+50 °C		-5 °C/+50 °C	
Incoming hose fitting	NO	NO	NO	NO
Incoming hose	1,5 m			
Suitable for	Air - Water			
Hose type	KPU		KPU SAFE	
Hose colour	BLUE		LIME	
	20			
	mm 450x400x230 - Kg 9			

AM86



ISO EN 12100



2006/42/EU



Compliant with Directives
2014/34/EU

Marking CE 
II 2 GD c IIB T4/T135° C X

Examination Certificate Number for
IMQ 14 ATEX 009 X

Compliant with Standards
EN 13463-1 : 2009 | EN 13463-5 : 2011

TECHNICAL FEATURES

- Metal, adjustable fastening bracket
- Provided with hose ratchet stop device, easily removable if constant traction is required.

Can be supplied with:

KPU hose. Technopolymer structure.
PVC, soft touch, scuff-resistant hose
NBR (SAE 100R6) extra-strong hose.

FIELDS OF USE



SAFETY RETURN



OPTIONAL ART. AM86/SR

Safety Return slows the retraction of the hose, preventing kickback should the hose accidentally slip out of the user's hand.

Safety Return is an optional braking device for the AM86 series.

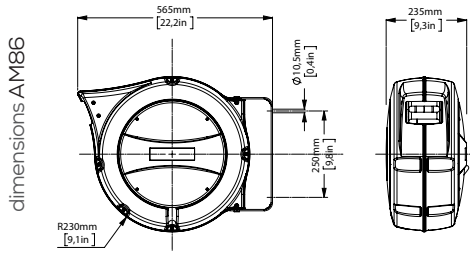

AM86 kpu



AM86 pvc



AM86 nbr



ART.	AM86/10	AM86/13	AM86/10 PVC	AM86/13 PVC	AM86/10 NBR	AM86/13 NBR
Hose Int. Ø	10 mm (3/8")	12,5 mm (1/2")	10 mm (3/8")	12,5 mm (1/2")	10 mm (3/8")	12,5 mm (1/2")
Hose length	25 m	16 m	20 m	12 m	18 m	12 m
Max press	15 bar	15 bar	15 bar	15 bar	15 bar	15 bar
End hose fitting	3/8" M BSP	1/2" M BSP	3/8" M BSP	1/2" M BSP	3/8" M BSP	1/2" M BSP
Incoming hose fitting	NO		NO		NO	
Temperature	-5 °C/+50 °C		-5 °C/+50 °C		-5 °C/+50 °C	
Incoming hose	1,5 m		1,5 m		1,5 m	
Suitable for	Air - Water		Air - Water		Air - Water	
Hose type	KPU		PVC		SAE 100R6	
Hose color	BLUE		BLUE		BLACK	
Atex			-		-	
	14					
	mm 550x505X270 - Kg 12					

AM86/FD



AM86/AGRI



TECHNICAL FEATURES

PU Food hose: certified for the food sector*

- Technopolymer casing.
- Metal, adjustable fastening bracket.
- Provided with hose ratchet stop device, easily removable if constant traction is required.
- Stainless steel end hose fitting

* REG. UE 1935/2004 AND REG. UE 10/2011 certified hose for use in the food industry. Not suitable for food liquids transfer.

TECHNICAL FEATURES

AGRI hose for professional agricultural sector

- Technopolymer casing.
- Metal, adjustable fastening bracket.
- Provided with hose ratchet stop device, easily removable if constant traction is required.

OPTIONAL

ART. AM86/FT



SAFETY RETURN

OPTIONAL ART. AM86/SR



14



mm 550x505x270
Kg 12

ART.	AM86/13 FD	AM86/AGRI
Hose Int. Ø	12,5 mm (1/2")	12,5 mm (1/2")
Hose length	12 m	18 m
Max press	15 bar	6 bar (0,6 Mpa)
End hose fitting	1/2" M BSP AISI 316 L	NO
Temperature	+5 °C/+65 °C	+5 °C/+40 °C
Incoming hose fitting	NO	NO
Incoming hose	1,5 m	1,5 m
Suitable for	Air - Water	Water
Hose type	PU - FOOD QUALITY*	PVC
Hose color	GREEN	YELLOW

ZETEX

Low pressure water gun with adjustable spray



	KPW050	KPW060	KPW060I
Body material	PP + GF	PP + GF	PP + GF
Piston material	Brass	Brass	Inox Aisi 316
Gasket material	Viton	Viton	Viton
Max. flow rate	50 l/min	60 l/min	60 l/min
Nominal pressure	12 bar / 1.2 MPa	24 bar / 2.4 MPa	24 bar / 2.4 MPa
Max working temp.	50 °C / 120 °F	60 °C / 140 °F	60 °C / 140 °F
Incoming fitting	Swivel G 1/2" F	Swivel G 1/2" F	Swivel G 1/2" F
Water jet width	Adjustment by handle: - fully pulled lever: needle jet - lever released: 60° cone jet	Adjustment screw ranging cone width from 0° to 60°	Adjustment screw ranging cone width from 0° to 60°

ZETEX

Automatic refueling nozzle

	ART. KPE060 D	Automatic refueling nozzle for gasoline 60 l/min
	ART. KPE090 D	Automatic refueling nozzle for gasoline 90 l/min
	ART. KPE060 U	Automatic refueling nozzle for AdBlue® 60 l/min



Not suitable for gas, petrol, oil, alcohol and water.



8400

ADJUSTABLE HOSE STOPPER

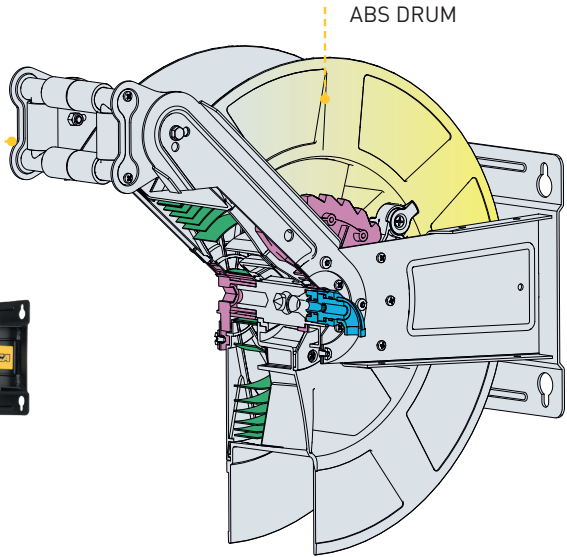

SUITABLE FOR



WATER



HIGH-PRESSURE WATER



OIL



AIR



GREASE



DIESEL



	SERIE 8400	SERIE 8400 LIGHT INOX	SERIE 8400 FULL INOX
Bracket	steel painted with epoxy resin powders	stainless steel AISI 304	stainless steel AISI 304
Rotating joint and incoming fitting	standard joint	standard joint	stainless steel
End pipe fitting	brass/steel	brass/steel	stainless steel
Screws and bolts	steel	stainless steel	stainless steel



Compliant with Directives
2014/34/EU

Marking CE Ex
II 2 GD c IIB T4/T135° C X

Examination Certificate Number for
IMQ 14 ATEX 009 X

Compliant with Standards
EN 13463-1 : 2009 | EN 13463-5 : 2011

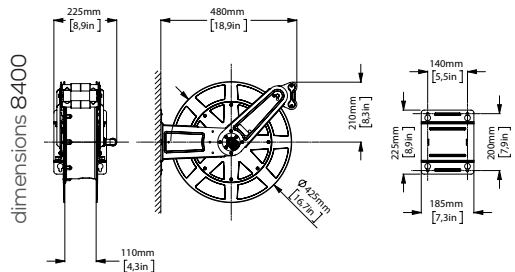

Max press	Suitable for	Hose type	Hose Int. Ø	Hose length	ART.		Fluid Temperature	End pipe fitting	Incoming fitting	
20 bar	Air Water	NO HOSE	/	/	8401	/	-15°C/+50°C	1/2" F	1/2" F	
			/	/	8480	AISI 316L joint				
		SAE 100R6	6 mm (1/4")	20	8412	/				1/4" M
			8 mm (5/16")	20	8402	/				3/8" M
			10 mm (3/8")	12	8404					1/2" M
			10 mm (3/8")	18	8406					3/8" M
			12,5 mm (1/2")	10	8408					1/2" F
			12,5 mm (1/2")	15	8410					3/8" M
			KPU	10 mm (3/8")	20	8424				
		12,5 mm (1/2")		15	8426					
12,5 mm (1/2")	20	8427								
15 bar	Water	PU-FOOD QUALITY*	12,5 mm (1/2")	12	8432	/	-10°C/+60°C	1/2" M	1/2" F	
	Diesel Oil	PVC - PU	19 mm (3/4")	8	8415	/	-10°C/+60°C	3/4" F swivelling	3/4" M	
	Ad Blue		19 mm (3/4")	8	8482	AISI 316L joint				
160 bar	Oil	EN 857 1SC	12,5 mm (1/2")	10	8474	/	-15°C/+120°C	1/4" F swivelling		
200 bar	Oil Water	NO HOSE	/	/	8440	/	-15°C/+130°C	1/2" F	3/8" F	
180 bar			EN 857 1SC Black	8 mm (5/16")	20	8441		/		3/8" F swivelling
		10 mm (3/8")		15	8442					
		EN 857 1SC Blue No Marking	10 mm (3/8")	18	8443					
10 mm (3/8")			15	8446						
10 mm (3/8")	18	8448								
400 bar	Oil Grease	NO HOSE	/	/	8460	/	-20°C/+120°C	1/2" F	3/8" F	
			EN 857 2SC	6 mm (1/4")	12	8462		/		1/4" M
		6 mm (1/4")		18	8463	/		1/4" M		

* REG. UE 1935/2004 AND REG. UE 10/2011 certified hose for use in the food industry.
Not suitable for food liquids transfer.

8400 LIGHT INOX

The **Light Stainless steel** hose reels are suitable for different fields of application, from the food industry to the shipping and chemical sectors, aggressive work environments with corrosive atmospheres. Ideal for industrial cleaning, blowing operations and for conveying fluids like oil.

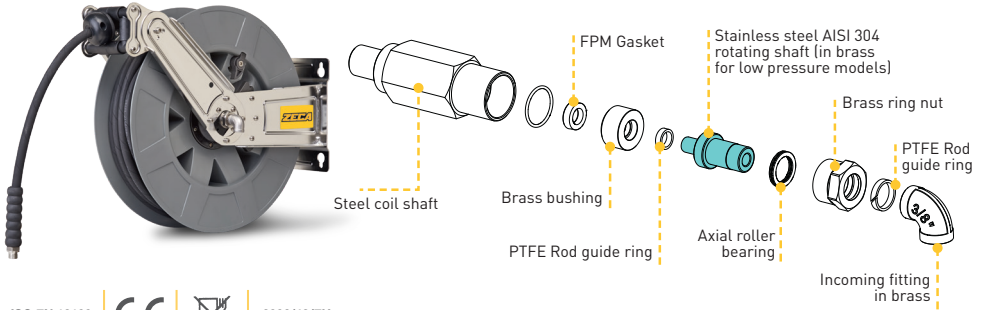

ISO EN 12100



2006/42/EU

Max press	Fluid type	Hose type	Hose Int. Ø	Hose length	ART.	Fluid Temperature	End pipe fitting	Incoming fitting
20 bar	Air Water	NO HOSE	/	/	8401/1003	-15°C/+50°C	1/2" F	1/2" F
		SAE 100R6	10 mm (3/8")	12	8404/1000		3/8" M	
			10 mm (3/8")	18	8406/1000			
		KPU	12,5 mm (1/2")	15	8426/1002		1/2" M	
			12,5 mm (1/2")	20	8427/1002			
15 bar	Water	PU FOOD QUALITY*	12,5 mm (1/2")	12	8432/1001	-10°C/+60°C	1/2" M	1/2" F
180 bar	Oil Water	NO HOSE	/	/	8440/1003	-15°C/+130°C	1/2" F	3/8" F swivelling
		EN 857 ISC Black	10 mm (3/8")	15	8442/1000			
			10 mm (3/8")	18	8443/1000			
		EN 857 ISC Blue No Marking	10 mm (3/8")	15	8446/1000			
			10 mm (3/8")	18	8448/1000			

* REG. UE 1935/2004 AND REG. UE 10/2011 certified hose for use in the food industry. Not suitable for food liquids transfer.

8400

FULL INOX

Full STAINLESS STEEL reels are the ideal for transport of fluids such as oil, AdBlue®, air and water, for industrial cleaning and blowing operations. They are perfect for different applications: food and drink industry, boating industry, chemical sector, heavy duty work environments and corrosive atmosphere.

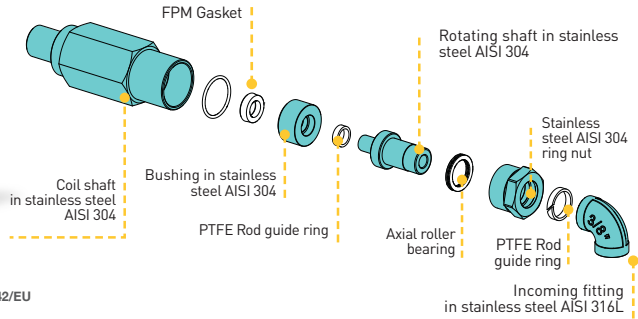

ISO EN 12100



2006/42/EU

Max press	Suitable for	Hose type	Hose Int. Ø	Hose length	Art.	Fluid Temperature	End pipe fitting	Incoming fitting
20 bar	Air Water	NO HOSE	/	/	8401/1113	-15°C/+50°C	1/2" F	1/2" F
		SAE 100R6	10 mm (3/8")	12	8404/1111		3/8" M	
			10 mm (3/8")	18	8406/1111		1/2" F	
		KPU	12,5 mm (1/2")	15	8426/1111		1/2" M	
			12,5 mm (1/2")	20	8427/1111			
15 bar	Water	PU FOOD QUALITY*	12,5 mm (1/2")	12	8432/1111	-10°C/+60°C	1/2" M	1/2" F
15 bar	AD Blue®	PVC-PU	19 mm (3/4")	8	8482/1111	-10°C/+60°C	3/4" F swivelling	3/4" M
180 bar	Oil Water	NO HOSE	/	/	8440/1113	-15°C/+130°C	1/2" F	3/8" F swivelling
		EN 857 1SC Black	10 mm (3/8")	15	8442/1111		3/8" F	
			10 mm (3/8")	18	8443/1111			
		EN 857 1SC Blue No Marking	10 mm (3/8")	15	8446/1111			
			10 mm (3/8")	18	8448/1111			

* REG. UE 1935/2004 AND REG. UE 10/2011 certified hose for use in the food industry. Not suitable for food liquids transfer.

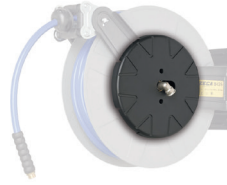
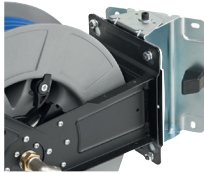
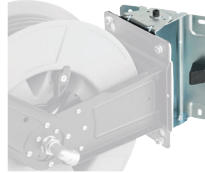
OPTIONAL SERIE 8400**COIL COVER****ART. 8400/CY**
Yellow coil cover**ART. 8400/CB**
Black coil cover**SWIVEL BRACKET****ART. 8400/SW**
Swivel bracket**ART. 8400/SWI**
Stainless steel
swivel bracket**INLET HOSE****ART. 8400/SL**

Inlet hose 60 cm - 20 bar - 1/2" SAE 100 R6 - fittings 1/2" M and 1/2" F rotating

ART. 8400/SK

Inlet hose 60 cm - 20 bar - 1/2" KPU - fittings 1/2" M and 1/2" F rotating

ART. 8400/SH

Inlet hose 60 cm - 200 bar - 3/8" 1SC black - fittings 3/8" M and 3/8" F rotating

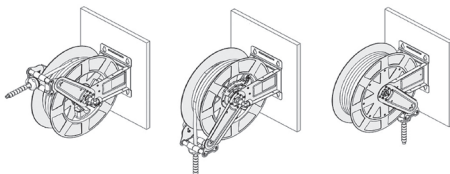
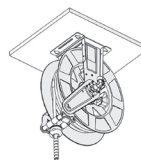
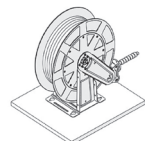
POSSIBLE INSTALLATION**WALL INSTALLATION****CEILING
INSTALLATION****BENCH
INSTALLATION**



TECHNICAL FEATURES



Mini-reel for applications in the industrial sector and for hobby.

- Monoextruded Polyurethan hose.
- Technopolymer casing.
- Provided with hose ratchet stop device, easily removable if constant traction is required.
- Working temperature: $-5^{\circ}\text{C}/+40^{\circ}\text{C}$.



ART.	9100/6	9100/8
Hose Int. Ø	5,5 mm	8 mm
Hose length	6,5 m	3,5 m
Max press	12 bar	12 bar
End hose fitting	1/4" M BSP	3/8" M BSP
Temperature	$-5^{\circ}\text{C}/+40^{\circ}\text{C}$	$-5^{\circ}\text{C}/+40^{\circ}\text{C}$
Incoming hose fitting	Ø 6x8	Ø 8x10
Incoming hose	NO	NO
Suitable for	Air - Water	Air - Water
Hose type	PU	PU
Hose color	BLUE	BLUE
	100	100
	mm 240x195x120 Kg 2	mm 240x195x120 Kg 2

dimensions 9100

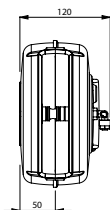
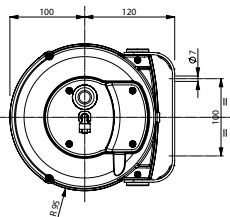

RECHARGEABLE LAMP LEDALUX

COB LED

TECHNICAL FEATURES

- Cob led light source.
- Designed to avoid the most common issues faced by professional led lamps users.
- It decreases the glare, even when the lamp is at eye level
- It spreads the light from the focal point with maximum brilliance and uniformity,
- Thanks to the reflective glass equipped with micro diffusers and inspired by the Fresnel lens concept.

ART.	39401
Description	COB LED rechargeable lamp
Light source	COB LED
Power	10 W + 4,5 W (SPOT)
Lux/Lumen	950 LUX @ 50 CM - 550 LUMEN
Angle	120°
Battery life	3 h standard mode 4h energy saving
Charging time	2,5h
Battery	3,7 V LiPo - 2600 mAh
	240x90x70 mm - 0,550 Kg

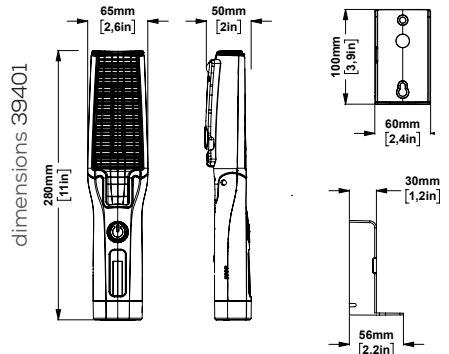

EN 60598-1
EN 60598-2-8
EN 60335-1



2014/35/UE
2011/30/UE
2011/65/UE



CAUTION: when the battery is almost flat, a red LED will light up on the lamp. When the switch no longer stays on, it means that the battery is flat and the lamp needs to be recharged.

COB LED

RECHARGEABLE LAMP 345

TECHNICAL FEATURES

- COB LED light source.
- Electronic control of the charge; the lamp can be kept always on the battery charger.
- Fixed red pilot light on the lamp:
flat battery.
Flashing red light: lamp in recharge.
Fixed green light: charge completed,
charge maintenance function.

ART.	345
Description	COB LED rechargeable lamp
Light source	COB LED
Power	4,5 W
Lux/Lumen	900 LUX @ 50 CM - 500 LUMEN
Angle	120°
Battery life	2,5h standard mode 4h energy saving
Charging time	3,5h
Battery	3,7 V LiPo - 4400 mAh
Battery charger	100/240 V (50/60 Hz) Output 5V 2A
	340x160x90 mm - 0,900 Kg



ART. 345

Rechargeable lamp + battery charger

ART. 345/12

Complete displayer with 12 lamps art. 345

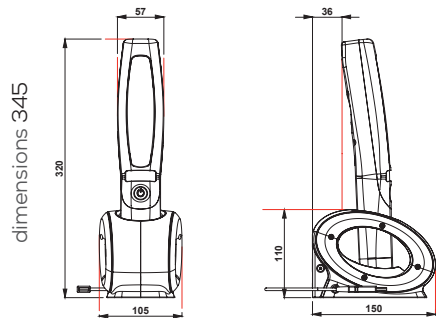

SPARE PARTS

ART. 345/VY - Transparent cover

ART. 345/L - Portable lamp only

ART. 345/C - Battery charger only

EN 60598-1
EN 60598-2-8
EN 60335-1



2014/35/UE
2011/30/UE
2011/65/UE



CAUTION: when the battery is almost flat, a red LED will light up on the lamp. When the switch no longer stays on, it means that the battery is flat and the lamp needs to be recharged.



RECHARGEABLE LAMP 342



TECHNICAL FEATURES

- 19 LED light source.
- Electronic control of the charge; the lamp can be kept always on the battery charger.
- Fixed red pilot light on the lamp:
flat battery.
Flashing red light: lamp in recharge.
Fixed green light: charge completed, charge maintenance function.

ART. 342

Rechargeable lamp + battery charger

ART. 342/9

Complete displayer with 9 lamps art. 342

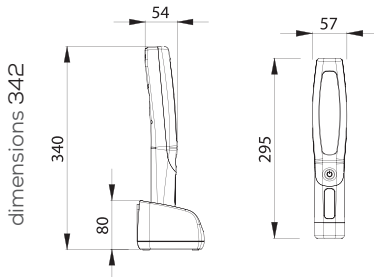

ART.	342
Description	LED rechargeable lamp
Light source	SMD LED
Power	1,5 W
Lux/Lumen	1500 LUX @ 50 CM - 160 LUMEN
Angle	15°
Battery life	4,5h standard mode 9h energy saving
Charging time	2,5h
Battery	3,7 V - 2200 mAh - Li-PO
Battery charger	100/240 V (50/60 Hz)
	130
	355x120x90 mm - 1 Kg

■ SPARE PARTS

ART. 342/VB - Transparent cover

ART. 342/L - Lamp only

ART. 342/C - Charging base

EN 60598-1
EN 60598-2-8
EN 60335-1





2014/35/UE
2011/30/UE
2011/65/UE













CAUTION: when the battery is almost flat, a red LED will light up on the lamp. When the switch no longer stays on, it means that the battery is flat and the lamp needs to be recharged.

COB LED 330 LAMP

- 2 power supply versions 230V and 24V.
- Protected switch.
- Retractable, rotating, adjustable hook.
- Replaceable transparent cover.
- Soft-touch handle. Protection degree IP64.

ART. 330 LAMP		Cable length	Lux Lumen	Power supply voltage		
 Lamp COB LED 4,5 W with cable	330/10 230V	10 m	900 LUX @ 50 CM	110-230V	60	mm 355x120x90 Kg 1,3
	330 230V	/		110-230V		
	330/10 24V	10 m	500 LUMEN	12-24Vdc-ac		
	330 24V	/		12-24Vdc-ac		

ART. CABLE REEL WITH LAMP 330		Cable length	Cable type	Power supply voltage		
	AL47/330 230V	15,5 m	H05 RN-F 2X1 mm ²	110-230V	40	mm 390x310x210 Kg 6
	5907/330 230V	15,5 m	H05 RN-F 2X1 mm ²	110-230V	60	mm 390x310x165 Kg 4
	AL47/330 24V	15,5 m	H05 RN-F 2X1 mm ²	12 - 24Vdc-ac	40	mm 390x310x210 Kg 6
	5907/330 24V	15,5 m	H05 RN-F 2X1 mm ²	12 - 24Vdc-ac	60	mm 390x310x165 Kg 4
	5908/330	15,5 m	H05 RN-F 2X1 mm ²	110-230V	60	mm 390x310x165 Kg 4
	9001/330 230V	8 m	H05 RN-F 2X1 mm ²	110-230V	60	mm 420x280x120 Kg 3
	9001/330 24V	8 m	H05 RN-F 2X1 mm ²	12 - 24Vdc-ac	60	mm 420x280x120 Kg 3

 **CAUTION:** use with different voltages than the ones indicated will irreparably damage the power circuit and invalidate the warranty.

EN 60598-1
EN 60598-2-8
EN 60335-1



2014/35/UE
2011/30/UE
2011/65/UE



FLUO 328 LAMP

- Electronic circuit in the handle.
- Protected soft touch switch.
- Rotating hook.
- Soft touch grip.





ART. 328 LAMP		Cable length	Lux Lumen	Power supply voltage		
<p>Lamp FLUO 11W with cable</p>	328/10 230V	10 m	280 LUX @ 50 CM	230V		mm 515x85x110 Kg 0,550
	328 230V	/		230V		
	328 10 24V	10 m	900 LUMEN	24Vac		
	328 24V	/		24Vac		





ART. CABLE REEL WITH LAMP 328	Cable length	Cable type	Power supply voltage		
<p>5907/328 230V</p>	15,5 m	H05 RN-F 2X1 mm ²	230V	60	mm 390x310x165 Kg 4
<p>5907/328 24V</p>	15,5 m	H05 RN-F 2X1 mm ²	24Vca	60	mm 390x310x165 Kg 4
<p>5908/328 + TRANSFORMER POWER: 14VA OUTPUT: 24V POWER SUPPLY: 230V</p>	15,5 m	H05 RN-F 2X1 mm ²	230V	60	mm 390x310x165 Kg 4
<p>9001/328 230V</p>	8 m	H05 RN-F 2X1 mm ²	230V	46	mm 420x280x120 Kg 3
<p>9001/328 24V</p>	8 m	H05 RN-F 2X1 mm ²	24V	46	mm 420x280x120 Kg 3

LED 329 LAMP

- Electronic circuit in the handle.
- Protected soft touch switch.
- Rotating hook.
- Soft touch grip.
- Available in two versions: 100–240V or 12–24V, with or without cable.

LAMP IP55
REEL IP42IK07 - SHOCK
RESISTANTENERGY
SAVING

ART. 329 LAMP		Cable length	Lux Lumen	Power supply voltage		
 <p>Lamp LED 2,5 W with cable</p>	329 10 230V	10 m	980 LUX @ 50 CM	110-230V		mm 515x85x110 Kg 0,550
	329 230V	/		110-230V		
	329 10 24V	10 m	140 LUMEN	12-24Vdc-ac		
	329 24V	/	12-24Vdc-ac			

ART. CABLE REEL WITH LAMP 329	Cable length	Cable type	Power supply voltage		
 <p>5907/329 230V</p>	15,5 m	H05 RN-F 2X1 mm ²	230V	60	mm 390x310x165 Kg 4
 <p>5907/329 24V</p>	15,5 m	H05 RN-F 2X1 mm ²	12 - 24Vdc-ac	60	mm 390x310x165 Kg 4,5
 <p>5908/329+ TRASFORMER POWER: 14VA OUTPUT: 24V POWER SUPPLY: 230V</p>	15,5 m	H05 RN-F 2X1 mm ²	230V	60	mm 390x310x165 Kg 4,5

The model with built-in transformer allows the portable lamp to be powered at low voltage (24V), for maximum user safety, as required by safety regulations.

All of our reels have a 1-metre incoming cable.

■ SPARE PARTS

ART. 529 Transparent cover

 **CAUTION:** use with different voltages than the ones indicated will irreparably damage the power circuit and invalidate the warranty.

EN 60598-1
EN 60598-2-8
EN 60335-1



2014/35/UE
2011/30/UE
2011/65/UE





370 LAMP

- Unbreakable plastic bell
- E27 screw bulb fitting
- For bulb with maximum power 60W
- Supplied without bulb
- Protected switch
- Retractable adjustable hook.

ART. 370 LAMP		Cable length	Power Lamp	Power supply voltage		
	370/10	10 m	Max 60W	max 250V	112	mm 370x145x135 1,4 Kg
	370	/	E27	max 250V	112	mm 370x145x135 0,6 Kg

ART. CABLE REEL WITH LAMP 370		Cable length	Cable type	Power supply voltage		
	5907/370	15,5 m	H05 RN-F 2X1 mm ²	Max 250V	60	mm 410x305x185 4 Kg
	5908/370 + TRASFORMER POWER: 14VA OUTPUT: 24V POWER SUPPLY: 230V	15,5 m	H05 RN-F 2X1 mm ²	230V	44	mm 345x300x220 4 Kg

The model with built-in transformer allows the portable lamp to be powered at low voltage (24V), for maximum user safety, as required by safety regulations.

All of our reels have a 1-metre incoming cable.

■ UNIVERSAL MAGNETIC BASE

ART. 050 Magnetic base for portable lamps including Velcro for retaining the lamp.





306 LAMP

- Anatomically shaped handle made of oil, acid, solvent resistant plastic.
- Hinged steel wire cage and galvanised sheet steel reflector.
- Protected switch in recessed slot.
- E27 bulb fitting.
- For bulbs with maximum power 60W.
- Rotating hook. Supplied without bulb.

ART. 306 LAMP		Cable length	Power Lamp	Power supply voltage		
	306/10	10 m	Max 60W	max 250V	115	mm 105x105x420 0,85 Kg
	T306	/	E27	max 250V	115	mm 105x105x420 0,45 Kg

ART. CABLE REEL WITH LAMP T306		Cable length	Cable type	Power supply voltage		
	5907/T306	15,5 m	H05 RN-F 2X1 mm ²	Max 250V	60	mm 390x310x165 4 Kg
	5908/T306 + TRASFORMER POWER: 14VA OUTPUT: 24V POWER SUPPLY: 230V	15,5 m	H05 RN-F 2X1 mm ²	230V	44	mm 345x300x220 6 Kg
	AM57/306	15,5 m	H05 RN-F 2X1 mm ²	Max 250V	40	mm 390x310x200 5 Kg

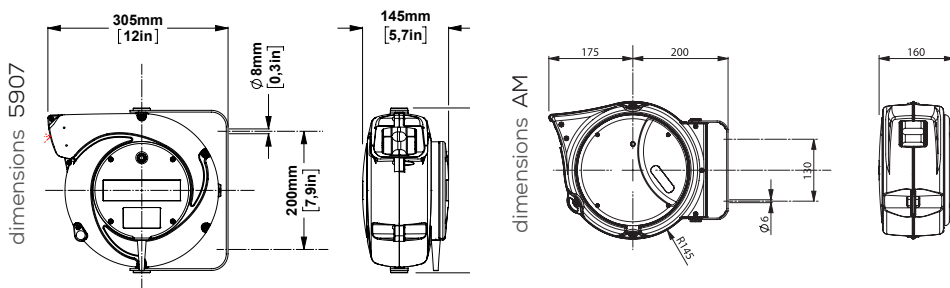

EN 60598-1
EN 60598-2-8
EN 60335-1



2014/35/UE
2011/30/UE
2011/65/UE

The unit 415, cooling system tester, is delivered with all these adaptors, that can also be individually purchased as spare parts.

ART. 415

RADIATOR TESTER

	ART.	
	416.05	FCA GROUP - PSA RENAULT - NISSAN MINI - VOLVO ROVER - MASERATI
	416.24	BMW
	416.55	SMART - PORSCHE
	416.30	FCA GROUP - OPEL SAAB
	416.40	FORD
	416.45	MERCEDES
	416.65	MERCEDES
	416.70	FIAT - SUZUKI TOYOTA MITSUBISHI
	416.80	MAZDA - FORD VOLVO
	416.85	BMW
	416.10	VW GROUP - FORD OPEL - SAAB CHEVROLET
	416.35	VW GROUP PORSCHE
	416.73 + 416.75	CARS WITH METALLIC CAP
	416.68 + 416.67	
	416.73 + 416.76	CARS WITH METALLIC CAP
	416.68 + 416.67	
	416.68 + 416.67	

OPTIONAL

ART. 416.60
Optional cap for Land Rover

ART. 416.81
Optional cap for Mercedes



COOLING SYSTEM TESTER

- Equipment for pressure testing the cooling system of cars.
- Delivered in a storage case complete with all adaptors for use on european and foreign cars.
- Supplied with long, flexible extension hose for difficult to reach radiators.
- The different adaptors are fitted with a quick coupler system.
- It enables the user to determine immediately any leak in the cooling system and any incidental failures:
 - faulty or worn hoses;
 - loose jubilee clips;
 - radiator leaks;
 - faulty cooling circuit;
 - burnt or badly settled cylinder head gaskets.

ART.415 COOLING SYSTEM TESTER
complete with adaptors.



48



475x385x110 mm
2,0 Kg

ART. 417

RADIATOR FILLER

FILLING OF COOLING SYSTEM WITHOUT GENERATING AIR BUBBLES



GENERAL FEATURES

Device for rapidly filling the cooling system of cars and trucks. The system works by vacuum and allows a rapid and complete filling of the cooling system without any need to start the vehicle several times during the filling operations. Vacuum is generated using compressed air. When a cooling system is filled with liquid, air bubbles are generated and these must be completely eliminated. Radiator Filler suits both cars and trucks. Together with the kit, 3 different size cones are supplied to fit different radiators. The device works on a system previously freed from any liquid and allows leak testing.

TECHNICAL DATA AND DIMENSIONS

- Working pressure from 5,5 to 12,0 bar
- Max air use 100 l/min at 6 bar
- Air connexion 1/4" F
- Temperature from -20° to +50°C
- Adapters: Ø 16 - 33 mm - Ø 23 - 41 mm
Ø 34 - 52 mm

ART.417 Radiator Fill



96

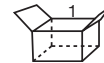

400x320x90 mm
1,5 Kg

Reduction of work time

Without radiator fill



20 min.

When filling the radiator in a traditional way air bubbles are generated. It is necessary to start the engine for a few minutes to bleed the circuit and refill again. This operation needs to be repeated several times.

With Zeca radiator fill



1 min.

When filling the radiator with the Zeca radiator fill Art.417 no bubbles are generated, no bleeding is needed and the operation is much faster.

ART. 362

PETROL ENGINE RECORDING COMPRESSION TESTER



- Recording card with wide scale approx. 50 mm of coated surface provides clear, accurate print out of test.
- Possibility of recording 8 tests on the card (+2 optional ones).
- Quick connection system for the spark-plug hole that expands due to pressure in cylinder to keep it in place.

ART. 362

Recording compression tester for petrol engines (with 48 spare cards, 5 spare rubbers and 1 adapter for M12 spark plug Art. 763).

■ SPARE PARTS

ART. 364 Set of 5 replacement rubbers

ART. 365 Set of 48 cards

ART. 763 Adapter for M12 spark plug

■ OPTIONALS:



ART. 762	Adapter for M10 spark plug.	
ART. 764	Adapter for M18 spark plug.	
ART. 765	Adapter M14 for Ford Zetec motors.	
ART. 766	Long adapter for M12 deep spark plugs. Length 190 mm.	
ART. 767	Long adapter for M14 deep spark plugs. Length 190 mm.	
ART. 768	Long adapter for M10 deep spark plugs. Length 190 mm.	



48



mm 475x385x110
2,5 Kg

ART. 363

DIESEL ENGINE RECORDING COMPRESSION TESTER

- Recording card with wide scale.
- Possibility of recording 8 tests on the card (+2 optional ones).
- Quick connector system for dummy injectors, no spanners necessary.

The compression tester comes complete with:

- 1 quick connector M14x1,5 for Zeca dummy injectors or original injectors. No spanners necessary.
- 1 connector M14x1,5 for use when the quick connector cannot be fitted.
- 1 connector M12x1,5 for original injectors.
- 48 recording cards.

To use the recording compression tester for diesel engines, it is necessary to use a dummy injector or heater plug suitable for the engine under test.



ART. 363

Recording compression tester for Diesel engines, delivered with 48 cards + 3 connectors, without dummy injectors.

■ SPARE PARTS

ART. 366

Set of 48 spare cards.

ADAPTOR LIST

WWW.ZECA.IT



48



mm 475x385x110
2,5 Kg

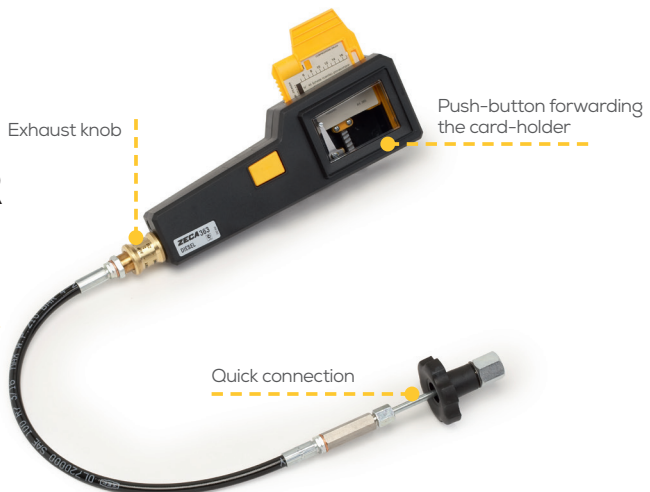

ART. 470/600 B

DIESEL INJECTOR TESTER

This injector tester is a bench-mounted hand-operated pump. Cracking pressure: controls nozzle function by examining if holes are obstructed and if there is back leakage, and by checking the spray pattern.

It can be used to check the tightness of the delivery pipe of the injection pump.

It can also be used as a general purpose pressure tester on pipes, tanks, pump castings, etc. where high pressure is required.

CAUTION: for the test, use the proper testing fluids according to ISO 4113 rules, viz. Shell Oil S. 9365.

ART. 470/600 B

Tester 600 Bar with connecting pipe art. 472 and 473.



42

 445x265x175 mm
4,5 Kg

■ SPARE PARTS

ART. 472

Connecting pipe M14x1,5 - M14x1,5

ART. 473

Connecting pipe M14x1,5 - M12x1,5.



ART. 430

ASPIRDIESEL, GAS-OIL STAEAM ASPIRATOR

Allows to improve visual checking of the injectors and, at the same time, to fully extract the fuel nebulized during the test and to canalize it into a proper collecting tank. The aspirator operates by compressed air, to guarantee highest safety. A supporting clip holds the injector steady during the test.



18

 mm 510x420x410
5,3 Kg

ART. 430 Diesel steam aspirator with quick connector art. 269 (delivered without pump).

ART. 269

QUICK CONNECTOR ADAPTOR FOR INJECTOR PUMP.

The quick connector adaptor enables the speedy attachment of Diesel pipes to injectors with threads 12 or 14 mm for testing, without the need of spanners.



ART. 675

TURBOZECA COMPRESSED-AIR EXHAUST GAS ASPIRATOR



CAR = 550 M3/H
AIR CONSUMPTION
330 LT/MIN



TRUCK = 790 M3/H
AIR CONSUMPTION
430 LT/MIN

- Air operated exhaust gas extractor.
- Adjustable aspiration power.
- Just one model for cars, vans, motorcycles and trucks.
- No moving parts.

The compressed air introduced into the device creates a highspeed flow inside the chamber that aspirates the exhaust gases. The aspiration power is easily adjustable by replacing the diaphragm on the air inlet. Two diaphragms are supplied with the exhaust gas extractor, one for use with cars and one for use with trucks and heavy duty vehicles.

On TurboZeca, the "Car" diaphragm is fitted as standard:

- capacity equivalent to centrifugal aspirator 550 m3/h
- air consumption 330 l/min. (compressor power about 4 HP)
- noise level 70 dB

By replacing the diaphragm with the "Truck" one, the aspirator becomes suitable for trucks:

- capacity equivalent to centrifugal aspirator 790 m3/h
- air consumption 430 l/min. (min. compressor power 5,5 HP)
- noise level 70 dB

Supply pressure 6 bar.

Minimum O of supply pipe 10 mm.

Connect the exhaust gas extractor to the filtered and notlubricated compressed-air line.

Mounted on trolley. Suitable for fitting CO2 control probes.

Rubber nozzle to protect the vehicle body.

Do not use during FAP regeneration operation.

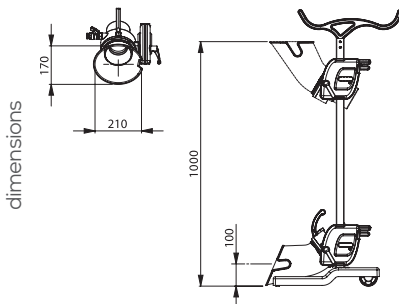

dimensions



mm 1180x400x510
Kg 14,00

ART.675

Turbozeca exhaust gas extractor complete with wheeled trolley, diaphragm for cars and trucks, pipe Ø 120 mm (4.8 inches) length 6 m (20 feet).

ART. 673

JUMBOZECA



GENERAL FEATURES

Portable Exhaust Gas Extractor designed to operate in any size workshop. Is an ideal alternative to fixed, space consuming, expensive systems. Suitable for use on cars, vans, motorcycles, light commercial vehicles, it allows the garage mechanic to work on the vehicle with the engine running, without causing pollution of the air or contravening the current workshop regulations. Mounted on a robust metal trolley with simple and easy to adjust height and suction setting. Suitable for fitting CO² probes. The Extractor outlet hose has a quick fit collar, for easy disconnection when moving from one location to another.

- 220 Volt engine. 50 Hz.
- Protection degree IP54.
- Supplied with 1,5 m of power cable, 3G1,5 mm² section.
- Delivered with 6 m plasticized heat-resistant (130°) ducting hose, 120 mm diameter, supported by a steel wire helix incorporated within 2 textile plies covered with self-extinguishing PVC.
- Capacity 430 m³/h.
- Max length outlet hose 18 m.
- Max height outlet hose 12 m.

OPTIONAL

ART.678

Additional Ducting Hose (6 metres).



mm 820x530x540
Kg 25,00

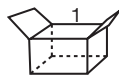

mm 390x390x220
Kg 3,00

ISO EN 12100-1
ISO EN 12100-2



2006/42/CE
2014/35/UE

ART. 673

Exhaust gas extractor with trolley and 6 m hose.



CAUTION: Do not use during FAP regeneration operation. Avoid tight elbows or constrictions of the outgoing hose.

ART. 298 - ART. 980

BATTERY FILLER

This filler is a battery distilled water dispenser which automatically stops pouring when the correct level is achieved in the battery cells. Manufactured in a special oil, acid and solvent resistant plastic, the automatic cut off level device is built into the nozzle. Refilling of the battery using this dispenser is quick, easy and accurate.

Manufactured in 2 different versions:

ART. 298 Fillerzeca: large filler with handle, capacity 2 litres.

ART. 980 Livell-Bat: small filler, capacity 1 litre.

■ SPARE PARTS

ART. 919 - Replacement nozzle for art. 298.

ART. 981 - Replacement nozzle for art. 980.

ART. 298

ART. 980



ART. 883 HOOK

Handle for lifting and transporting batteries. Ensures stable anchoring without the risk of slipping. The safety lock allows the battery to be released only when it is placed down.



ART. 920 HYDROMETER

Standard tool for measuring the specific density of battery electrolyte. Each measurement will show the condition of the individual cells of a battery. **ART. 920** - Glass hydrometer.

ART. 977/15

POLINET - CLEANING BRUSH

Cleaning brush designed to quickly and efficiently remove acid deposits from battery poles and terminals.

ART. 977/15 - 15 Polinet per package.

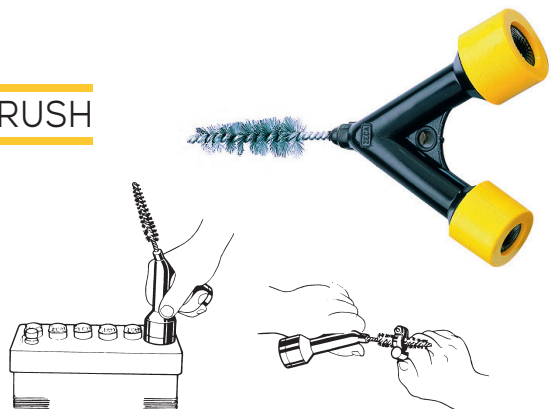

ART. 152

COOLANT ANTIFREEZE TESTER



Allows to check and reset ethylene glycol antifreeze (normal antifreeze). Quick and easy to use, it allows to determine, with fair approximation, the freezing point of the water/antifreeze coolant.

The device calibration is obtained by taking, as a basis for the liquid under test, a temperature of around 50°.

ART. 152 - Glass antifreeze tester for antifreeze, based on ethylene glycol.

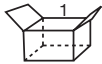

mm 420x95x90
0,2 Kg

ART. 403

TOOL FOR ADJUSTING CLUTCH PLATES

The adjustment is directly carried out between the clutch plate and the pressure plate and they become joined to the tool and are reassembled as a homogeneous body on the flywheel. Provides ease of installation and alignment without using the pilot bearing.

ART. 403 - Universal tool for adjusting clutch plates.

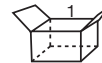

mm 300x120x80
0,4 Kg

ART. 209

COMPRESSED AIR VALVE GRINDER



UNI ENV 25349
ISO EN 12100-1
ISO EN 12100-2



2006/42/CE

■ SPARE PARTS

ART. 235 Small rubber suction pad \varnothing 22 mm

ART. 236 Medium rubber suction pad \varnothing 33 mm

ART. 237 Large rubber suction pad \varnothing 40 mm

ART. 239 Universal joint

ART. 240 Reducer \varnothing 7 mm

ART. 241 Reducer \varnothing 9 mm

ART. 242 Two screwdrivers

ART. 244 Reducer \varnothing 6 mm

An essential tool in any workshop for a quick valve grinding. Robustly made, light, practical and easy to handle, it can be used even by inexperienced operators. Air consumption is greatly reduced. Speed control is achieved by increasing or decreasing air flow. This equipment uses a standard air line and features left and right alternate rotation to simplify valve grinding and reduce operator fatigue. Comes complete with a number of suction pads and accessories.

ART. 209 Compressed air valve grinder with accessories.



96



mm 400x320x90
1,5 Kg

ZECA CLIPS



ART. 925



ART. 926



ART. 314



ART. 322

- Strong clips made of galvanized steel sheet.
- Spring of galvanized steel.
- Insulated plastic handles, oil/acid/solvent-resistant.

ART.	A	LENGTH	WEIGHT	COLOURS
926	400	215 mm	580 gr	R= red / N= black
925	220	215 mm	400 gr	R= red / N= black
314	150	176 mm	140 gr	R= red / N= black
322	40	80 mm	25 gr	R= red* / N= black*

*Minimum quantity: 10 PCS

BOOSTER CABLES Art. 315

ART.	CABLE SEC.	CABLE LENGTH	CLIPS
315/3, 5/16	16 mm ²	3,5 m	mod. 314
315/3, 5/25	25 mm ²	3,5 m	mod. 925
315/4, 5/25	25 mm ²	4,5 m	mod. 925



INSULATED CLIP Art. 923

ART. 923 INSULATED CLIP

- Brass clips capacity 200A
- Very strong spring to always assure a good contact.
- Max 48V.

ART. 923 N Insulated clip, capacity 200 A, black.

ART. 923 R Insulated clip, capacity 200 A, red.



INSULATED CLIP Art. 320

ART. 320 INSULATED CLIP

- Brass clips capacity 200A
- Very strong spring to always assure a good contact.
- Cables up to a max of 16mm² - Max 48V.

ART. 320 N Insulated clip, capacity 200 A, black.

ART. 320 R Insulated clip, capacity 200 A, red.



ART. 210

BATTERY AND ALTERNATOR TESTER



STANDARD	A
	RANGE
EN	50-3000
EN2	50-3000
DIN	50-1800
IEC	50-2000
SAE	50-3000



BATTERY AND ALTERNATOR TESTER

- 12 V battery test.
- 12 V cars and trucks alternator test.
- Simple and accurate use.
- Test time: 15 seconds!
- Battery test according to standard: EN - EN2 - DIN - IEC - SAE - JIS.
- Suitable for standard batteries, Gel technology, VRLA, AGM and SLA.
- Temperature compensation.
- Double contact insulated clips (Kelvin connection).
- Test made at low current, without sparks or overheating so not to damage the electronic unit.
- The test doesn't drain the battery.
- 2x16 characters display at high visibility, with Led backlighting.
- Reading possibility in 6 languages.
- Polymer box, with soft-touch protection shell.



96

 mm 400x320x90
1,5 Kg

 2014/30/UE
2011/65/UE

ART	DESCRIPTION	DISPLAY LANGUAGE		
210	Battery and alternator tester	Italian	English	French
		German	Spanish	Dutch
211	Battery and alternator tester	Italian	English	Finnish
		German	Swedish	Greek



This is a dual purpose tester.

Battery charge state: the test is performed with the load resistors connected; the gauge will accurately indicate the charge state of the battery.

Regulator calibration: the test is performed with the load resistors disconnected. The gauge will show the setting of the voltage regulator and the output of the generator. It is also possible to use the tool for checking the voltage drop in the battery when starting the engine.

ART. 207

BATTERY TESTER

GENERAL FEATURES

Precision tool with moving coil. - Clear separate scales for both 6 and 12 Volt.

ART. 207 Battery tester.



mm 120x115x335
0,70 Kg



MORE TOOLS FOR BATTERIES
available on Zetek catalogue



ART. 450

SPIKE SUPPRESSOR

ELECTRONIC CONTROL UNIT SURGE PROTECTOR 12 - 24 V

Designed to protect on-board electronics from the voltage spikes that may occur while employing electric power from an external source for fast starting purposes (battery connected to another vehicle or booster). This appliance is simple and quick to use. Connect the two clamps to the battery poles. The red light indicates operating

voltage (12V/24V). The buzzer sound indicates the presence of voltage spikes that the surge protector is dispelling.

ART. 450 Electronic control unit surge protector
12 - 24 V



mm 250x190x55
0,30 Kg



TRANSIENT VOLTAGE SUPPRESSION DEVICE (TVS) DATA:

RATED BATTERY VOLTAGE		12V	24V
Rated working peak voltage (Rated stand off voltage)		17,1V	31,4V
Breakdown voltage (min. clamping voltage)		18V	33V
Maximum clamping voltage	8/20μS	32,5V / 308A	59,0V / 169A
	10/1000μS	25,2V / 59,5A	45,7V / 33A
Peak pulse power dissipation 10/1000μS		1500W	1500W

SAFETY

BARRIERS REEL



LENGTH
TAPE

RED
WHITE
RW models

YELLOW
BLACK
BY models

HANDY
FASTENING
HOOK



GENERAL FEATURES

ISO EN 1200
2006/42/EC

Delimiter cable reel, temporary barriers to cordon off a specific area or signal hazardous areas.

Available in 3 lengths:

- 8 metres art. 9801
- 16 metres art. 5801
- 20 metres art. 4801

All the tapes are made of polypropylene

It comes complete with a technopolymer hook, safer for the operator

5801/RW - 5801/BY

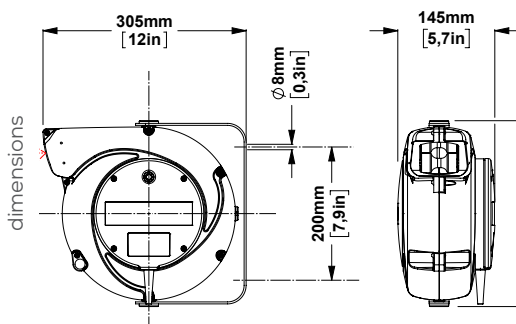



ART.	4801 RW	4801 BY	5801 RW	5801 BY	9801 RW	9801 BY
Description	Automatic cable reel with metal hook					
Tape length	m. 20		m. 16		m. 8	
Tape colour						
	44		57		100	
	mm 360x310x185 Kg 3,5		mm 305x300x155 Kg 4,0		mm 240x195x120 Kg 1,5	



4801/RW - 4801/BY

9801/RW - 9801/BY

dimensions

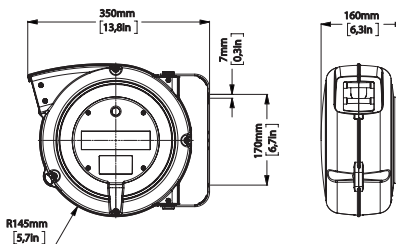



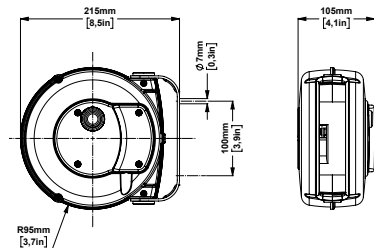

dimensions



Extension reels

Reel with spring retraction mechanism, suitable for use as extensions, allows the user to have a power supply available at all times.

Model		Cable length	Cable type	ART.	Color	W  (20°C) 230V	W  (20°C) 230V
	Extension reel	15 m	3G1,5-PVC	4315	Silver	1200	1800
	Extension reel	15 m	3G1,5-PVC	4315/S	Yellow	1200	1800
	Extension reel	15 m	3G2,5-PVC	4325/15	Yellow	1900	2500
	Extension reel with Schuko socket and plug	15 m	3G1,5-PVC	4315/GS	Yellow	1200	1800
	Extension reel with Schuko socket and plug	15 m	3G1,5-PVC	4315/SGS	Silver	1200	1800
	Extension reel with 3 Schuko sockets and plug	15 m	3G1,5-PVC	4315/GS3	Yellow	1200	1800
	Extension reel with 3 Schuko sockets and plug	15 m	3G2,5-PVC	4325/15/A/GS3	Azure	1900	2500
	Extension reel with Schuko socket and plug	10 m	3G2,5-PVC LIME	4325/GS SAFE	Black	1900	2500
	Extension reel with Schuko socket and plug	22 m	3G2,5-PVC LIME	7325/GS SAFE	Black	2000	3000

- Metal, adjustable fastening bracket
- Cable ratchet stop device.
- With incorporated thermic protection
- Double earth contact.
- Working temperature: -5°/+50°C.

Model	Cable length	Cable type	ART.	Color	W  (20°C) 230V	W  (20°C) 230V
 Extension reel	15 m	3G1,5-PVC	AL41/315	Silver	1200	1800
 Extension reel	15 m	3G1,5-PVC	AL41/315/B	Black	1200	1800
 Extension reel with 3 Schuko socket and plug	15 m	3G1,5-PVC	AL41/315 GS3	Silver	1200	1800
 Extension reel with 3 Schuko socket and plug	15 m	3G1,5-PVC	AL41/315/B GS3	Black	1200	1800
 Extension reel with Schuko socket and plug	15 m	3G1,5-PVC	AL41/315/B GS	Black	1200	1800
 Extension reel	15 m	3G1,5-PVC	AM40/315	Gray	1200	1800
 Extension reel	6 m	3G1,5-PVC	9004	Black	1400	1900
 Extension reel with Schuko plug and socket	6 m	3G1,5-PVC	9004/GS	Black	1400	1900

3500 SERIES

HAND OPERATED CABLE COILERS

REEL
LOCK BRAKE

INTERNAL BODY
IN PLASTIC FOR
MAXIMUM SAFETY

GALVANISED
FLANGE

STEEL PIPE
STAND,
OVEN COATED.



All the models are "CE" marked except incomplete models (without sockets and/or without cable), where "CE" marks must be placed by whom fits sockets and/or cables and puts on the market.

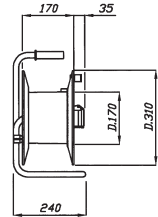
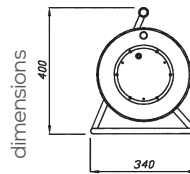

EN 61242
EN 60335-1



2014/35/UE
2011/65/UE

Socket type		No cable	Metres of cable	ART.	Type of cable	W	Circuit breaker
	no sockets	-	NO cable	3501	-	-	NO
	4 sockets 10/16 A 2P+T Schuko (schuko/france plug)	- 3G1.5 3G1.5 3G2.5 3G2.5	NO cable 25 40 25 40	3507 3508 3509 3510 3511	- PVC PVC PVC PVC	- 1400 1200 2100 1800	YES YES YES YES YES
	2 sockets 10/16 A 2P+T Schuko 1 socket (blue) CEE 16A (plug CEE 16A 2P+T)	- 3G1.5 3G1.5 3G2.5 3G2.5	NO cable 25 40 25 40	3512 3513 3514 3515 3516	- PVC PVC PVC PVC	- 1400 1200 2100 1800	YES YES YES YES YES
	2 socket (blue) CEE 16A (plug CEE 16A 2P+T)	- 3G1.5 3G1.5 3G2.5 3G2.5 3G2.5	NO cable 25 40 25 40 30	3517 3518 3519 3520 3521 3526	- PVC PVC PVC PVC RUBBER	- 1400 1200 2100 1800 1800	YES YES YES YES YES YES
	2 socket (red) CEE 16A 16 A 3P+T 380V (plug CEE 16A 3P+T)	- 4G1.5 4G1.5 4G2.5 4G2.5	NO cable 25 40 30 30	3522 3523 3524 3525 3527	- PVC PVC PVC RUBBER	- 2200 1900 2500 2500	NO YES YES YES YES

9000 SERIES

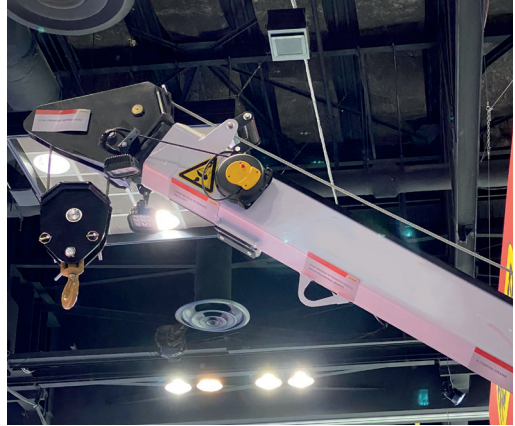

TECHNICAL FEATURES

Shock resistant plastic external case.
 Ratchet stop device every 50 cm easily removed if constant traction of cables is required. Protection degree IP42.
 Slipping with brass rings and brushes.
 Working temperature: $-5^{\circ}\text{C}/+50^{\circ}\text{C}$.
 Double earth contact.

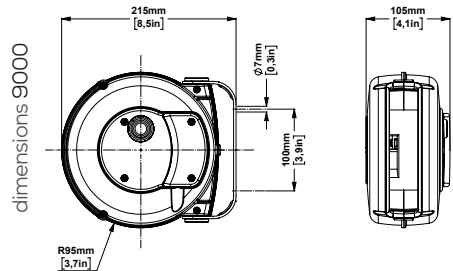

Number of conductors	Conductor sections (mm ²)	Cable length (m)	ART.	KW (20°C)		Cable mm Ø	Thermal switch	Max V	Cable type		
1x	6		9006			5,5	NO		PVC ■ ■		
2x	1	8	9001	230V	1,1	230V	1,6	6,5	SI	500	PVC
	1,5	6	9002		1,4		1,9	8	SI	500	PVC
3 G	1	7	9003		1,1		1,6	6,5	SI	500	PVC
	1,5	6	9004		1,4		1,9	7,5	SI	500	PVC



100



mm 240x195x120
Kg 2,0

EN 61242
EN 60335-1



2014/35/UE
2006/42/UE
2011/65/UE



4000 SERIES

TECHNICAL FEATURES

- Shock resistant plastic external case
- Cable roller guide
- Ratchet stop device every 50 cm., easily removed if constant traction of cable is required
- Double earth contact
- Collector insulation voltage 2,5 KV.
- Specific slip ring developed by Zeca
- Working temperature -5°C/+50°C
- Delivered without cable at feeding side
- Available both with PVC cable and rubber cable.

dimensions 4000

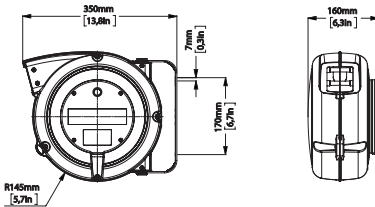

The most popular models are shown above. The full range is shown in our general catalogue or visit our website www.zeca.it.

Number of conductors	Conductor cross-sections (mm ²)	Cable length (m)	ART.	ART. IP 65	KW (20°C)		Cable mm Ø	Thermal switch	Max V	Cable type			
2x	1	18	4210	4210 IP65	230V	0.9	14	6	YES	500	PVC		
		13	4210 RNF	-				8	YES	750	RUBBER		
	15	4215	-	16			8	YES	500	PVC			
3G	15	15	4315			4315 IP65	12	230V	18	7	YES	500	PVC
		10	4315 RNF	4315 RNF IP65		9.5				YES	750	RUBBER	
	2.5	10	4325	4325 IP65		19	2.5		10	YES	500	PVC	
		15	4325/15	-	8.5				YES	500	PVC		
		8	4325 RNF	4325 RNF IP65	11.5				YES	750	RUBBER		
4G	15	11	4415	4415 IP65	400V	1.4	19	8.5	NO	500	PVC		
		9	4415 RNF	-				10.5	NO	750	RUBBER		
	2.5	9	4425	4425 IP65			2.0	400V	2.7	11	NO	500	PVC
		6	4425 RNF	-						12.5	NO	750	RUBBER
5G	1	11.5	4510	-		1.0	19		15	NO	500	PVC	
		9	4515	-					9.5	NO	500	PVC	
	15	4515 RNF	-	14				12	NO	750	RUBBER		



7000 SERIES

dimensions 7000

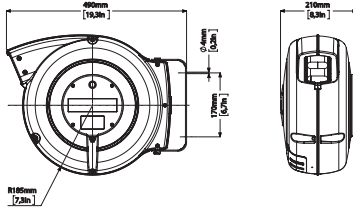

TECHNICAL FEATURES

- Shock resistant plastic external case
- Cable roller guide
- Ratchet stop device every 50 cm., easily removed if constant traction of cable is required
- Double earth contact
- Collector insulation voltage 2,5 KV.
- Specific slip ring developed by Zeca
- Working temperature -5°C/+50°C
- Delivered without cable at feeding side
- Available both with PVC cable and rubber cable.

Number of conductors	Conductor cross-sections (mm ²)	Cable length (m)	ART.	KW (20°C)		Cable mm Ø	Thermal switch	Max V	Cable type		
1x	16	22	7116			8	NO		PVC		
2x	1.5	27	7215	230V	11	18	8	NO	500	PVC	
3G	1.5	27	7315		11		7	NO	500	PVC	
		22	7315 RNF		2.0	9.5	NO	750	RUBBER		
	22	7325	10			NO	500	PVC			
	2.5	25	7325/25			8.5	NO	500	PVC		
		19	7325 RNF			11.5	NO	750	RUBBER		
	4G	1.5	27		7415	400V	11	18	8.5	NO	500
18			7415 RNF		10.5				NO	750	RUBBER
2.5		20	7425		2.0		3.0	11	NO	500	PVC
		15	7425 RNF					12.5	NO	750	RUBBER
5G	1.5	22	7515	15			2.2	9.5	NO	500	PVC
		17	7515 RNF					12	NO	750	RUBBER
	2.5	17	7525	2.0	3.0		12.5	NO	500	PVC	
		12	7525 RNF				13.5	NO	750	RUBBER	

SAFETY RETURN

Safety Return allows the slowed down rewinding of the cables, avoiding dangerous blowbacks in case the operator loses his grip on the cable. Safety Return is an optional braking device for entire Zeca 7000 series.



20



mm 450x400x225
Kg 8,0 - 10,0

AL BLACK SERIES



TECHNICAL FEATURES

- Die-cast aluminium structure painted with black epoxy powder.
- Cable roller guide
- Ratchet stop device every 50 cm.
All cable reels are supplied with predisposition for cable-stop device off.
- Double earth contact
- Collector insulation voltage 2,5 KV.
- Specific slip ring developed by Zeca
- Slipring with brass rings and brushes
- Working temperature -5°C/+50°C
- Delivered without cable at feeding side
- Available both with PVC cable and rubber cable.

EN 61242
EN 60335-1



2014/35/UE
2006/42/UE
2011/65/UE

■ **OPTIONALS:** ▶ **SAFETY RETURN** ◀◀
ART. AL71-AM70/SR

Number of conductors	Conductor cross-sections (mm ²)	Cable length (m)	ART.	KW (20°C)		Cable type		
3 G	2.5	15	AL41/325/15/B	230V	230V	PVC		
3 G	1.5	27	AL71/315/B			1.9	2.5	PVC
3 G	1.5	22	AL71/315/B RNF			1.1	1.8	PVC
3 G	2.5	22	AL71/325/B			1.1	1.8	RUBBER
3 G	2.5	19	AL71/325/B RNF			2.0	3.0	PVC
3 G	2.5	25	AL71/325/25/B			2.0	3.0	RUBBER
4 G	1.5	18	AL71/415/B RNF			2.0	3.0	PVC
4 G	2.5	15	AL71/425/B RNF			1.5	2.2	RUBBER
5 G	1.5	17	AL71/515/B RNF			2.0	3.0	RUBBER
5 G	2.5	12	AL71/525/B RNF			1.5	2.2	RUBBER
						2.0	3.0	RUBBER



EV REELS SERIES



Tidiness

No more tangled cables in the way.



Time saving

Charging your car will be much simpler and quicker



Cleanliness

Your hands won't get dirty because there is no direct contact with the cable.



Safety

Cables are safely stored without the risk of getting caught

REEL



POWER
up to 11 Kw

CABLE LENGTH
5/6 metres



POWER
up to 22 Kw

CABLE LENGTH
8 metres

WALLBOX + REEL



POWER
3.8 Kw

CABLE LENGTH
5 metres



ALSO AVAILABLE WITH WI-FI

EV3 REEL+WALLBOX

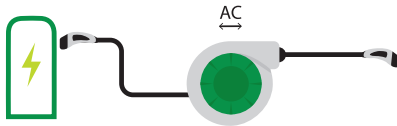

EV3WB REEL + WALLBOX

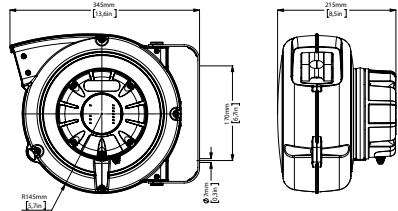

ART.	Cable	Charger	Outlet socket	Cable Length	IP protection rating	Wi-fi
EV3161WB+	3G2,5 + 1x0,5	single phase 16A (3,8 Kw)	TYPE 1	5 m	IP 42 (IP44)*	✓
EV3161WB	3G2,5 + 1x0,5	single phase 16A (3,8 Kw)	TYPE 1	5 m	IP 42 (IP44)*	
EV3162WB+	3G2,5 + 1x0,5	single phase 16A (3,8 Kw)	TYPE 2	5 m	IP 42 (IP44)*	✓
EV3162WB	3G2,5 + 1x0,5	single phase 16A (3,8 Kw)	TYPE 2	5 m	IP 42 (IP44)*	

* IP 42 Reel (IP44 Plug)*

**EV3
REEL**



**EV4
REEL**



YOUR
WALLBOX

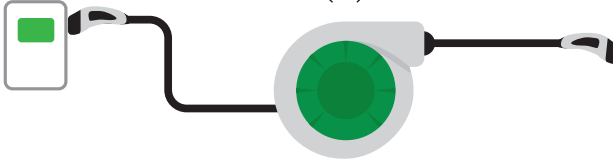

CONNECTED TO
YOUR WALLBOX,
FOR CHARGING
IN COMPLETE SAFETY.

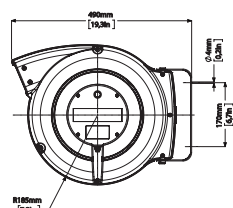
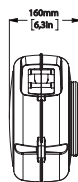
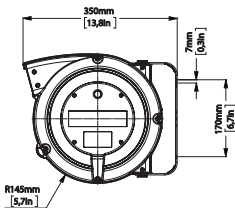

ART.	Cable	Charger	Inlet plug	Outlet socket	Cable length	IP protection rating
EV3161	3G2,5 + 1x0,5	single phase 16A (3,8 Kw)	TYPE 2	TYPE 1	5 m	IP 42 (IP44)*
EV3162	3G2,5 + 1x0,5	single phase 16A (3,8 Kw)	TYPE 2	TYPE 2	5 m	IP 42 (IP44)*
EV4162T	5G2,5 + 1x0,5	three-phase 16A (11 Kw)	TYPE 2	TYPE 2	6 m	IP 42 (IP44)*

* IP 42 Reel (IP44 Plug)

EV6

REEL

for charging
electric vehicles



ART.	Cable	Charger	Inlet plug	Outlet socket	Cable length	IP protection rating
EV6321	3G6 + 1x0,5	single phase 32A	TYPE 2	TYPE 1	8 m	IP44
EV6322	3G6 + 1x0,5	single phase 32A	TYPE 2	TYPE 2	8 m	IP44
EV6162T	5G2,5 + 1x0,5	three-phase 16A	TYPE 2	TYPE2	8 m	IP44
EV6322T	5G6 + 1x05	three-phase 32A	TYPE 2	TYPE 2	8 m	IP44

dimensions EV6

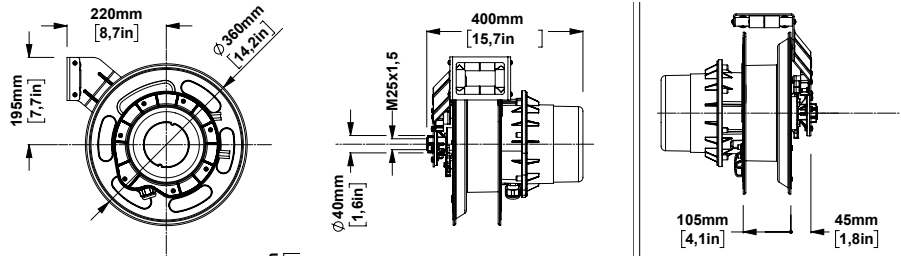

OPTIONAL ACCESSORIES

ALL THESE OPTIONAL ACCESSORIES ARE SUPPLIED DISASSEMBLED

SWIVEL BRACKET ART. 1401 W

- Only suitable for manual use.
For wall installation

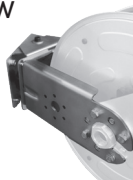

FIXED BRACKET ART. 1403

- for wall,
floor or ceiling installation.



ART. 4216



CABLE REEL FOR BATTERY CHARGER

Cable reels designed to facilitate the connection between the battery charger and the battery being charged.

ART. 6216



ART. 1425

TECHNICAL FEATURES

Max voltage 48V

All reels are provided with insulated clips, black and red, capacity 200A and length 160mm.

The models Art.1424 and 1425 are provided with roller cable guide and ratchet Art. 1406

EN 61242
EN 60335-1



2011/65/UE
2006/42/UE



no. of conductors	cross-section (mm ²)	cable length (m)	ART.	collector capacity (A)	cable type	∅ cable (mm)	A	A	IP rating*	incoming cable length (m)
2 X	9	6	4216	30	PVC	13	20	30	IP42	1
		9	6216	30	PVC	13	20	30	IP42	2
	20	12	1425	100	TPE	17,5	50	100	IP65	2
	32	17	1796	150	PVC	20,5	80	150	IP65	2

* IP rating refers to reels without clips

GF/0924/2000

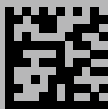

010.0242R



Strada della Chiara, 25
10080 Feletto Canavese (To) Italy
Tel. Export +39 0124 499630
export@zeca.it

ZECA.IT

